

THE NEXT GENERATION



PROBELL
TOP HAT SERIES
BELLHOUSINGS



THE NEXT GENERATION

IN BELLHOUSINGS

PROBELL INTRODUCES THE **TOP HAT** **SERIES**

For the first time in over thirty years someone has designed a better bellhousing. It's about time. We wanted to do something better so we talked to racers who drive dragsters, funny cars, nostalgia cars, truck and tractor pullers and more to ask what improvements they would like in a bellhousing. Racers are the real Top Hat designers, because we took what they told us and turned it into reality.

Top Hat bell housings have the smallest formed starter pocket in the industry so they fit in the narrowest chassis available. They are completely CNC machined for accuracy to ensure a perfect fit to your engine and transmission. Top Hats also have the largest inspection window allowed by SFI specifications and cross shaft supports to eliminate cross shaft deflection. We are also the only manufacturer with a solid formed liner in our 6.2 & 6.3 bell housings.

You can buy standard Top Hat bell housings in depths from 6-7/16" to 9-7/16" to fit

everything from single disc to a six-disc top fuel clutch. Tip your hat to Top Hat. The next generation in SFI bell housings.

INTRODUCING PERFORMANCE COMPLIANCE KITS

Top Hat bell housings include everything you need to comply with class rules requiring Blow Back Brackets and Clutch / Bellhousing exhaust filters. We've included these features, plus cross shaft supports that eliminate cross shaft deflection and improve clutch release and reaction times. For one great price, you get everything you need.

All 6.2 SFI certified bell housings come complete with Performance Compliance Kits.

Kits are optional with 6.3 SFI certified bell housings.

HIGHEST QUALITY MATERIALS

PRECISION CNC MACHINED

SUPERIOR QUALITY & SERVICE

MADE IN THE USA

If it doesn't say PROBELL, it's just a CAN.

TOP HAT BELLHOUSINGS

QUALITY IS THE DIFFERENCE IN OUR CANS

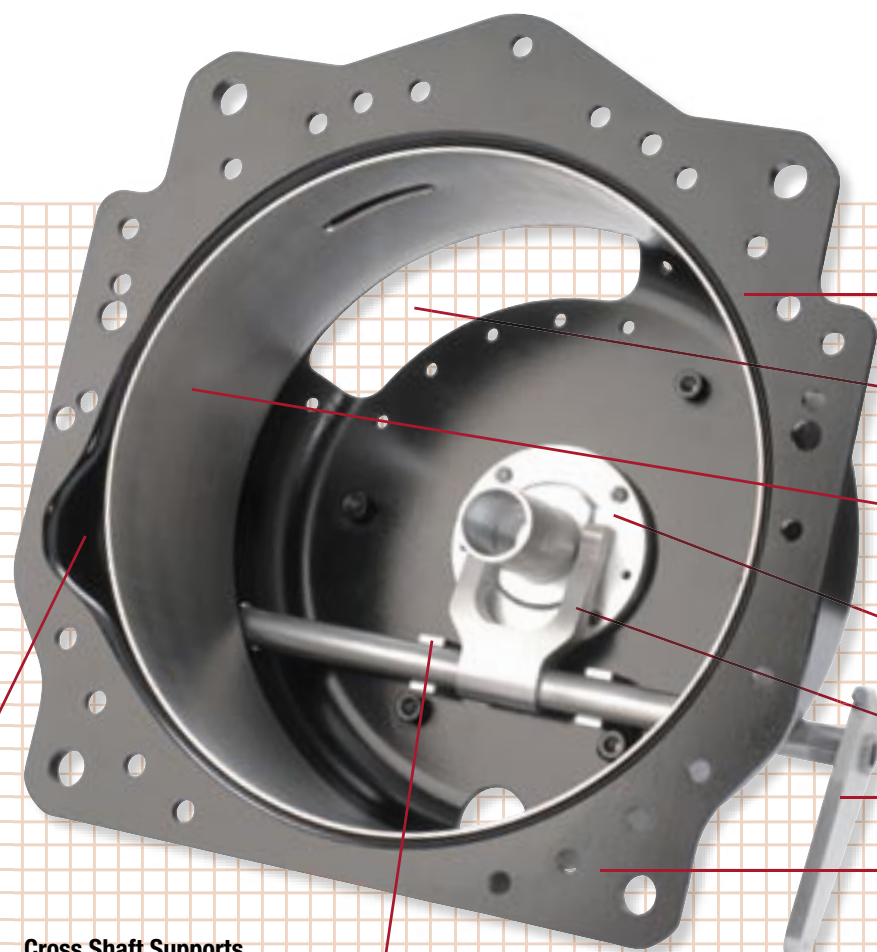

Completely CNC Machined
for accuracy and quality

Inspection Window with Cover
Largest allowed by SFI Specifications
(cover not shown)

Formed One Piece Liner
for maximum strength
(standard on 6.2 & 6.3 models)

Billet Aluminum Bearing Retainer
with computer pickups

Billet Steel or Aluminum Clutch Fork

Billet Aluminum Shaft Arm

Highest Quality
Mill Certified Material

3/4" Anti Rotators
for maximum safety
(standard on 6.2 & 6.3 models)

Cross Shaft Supports
to eliminate cross shaft deflection

Smallest formed Starter Pocket in the industry

Powder Coated for durability

Blow Back Brackets
standard on 6.2 models
(optional on 6.3 & 6.1 models)

Cross Shaft splined both ends

1 1/2" Cooling Hole
standard on 6.3 & 6.1 models

Filter Vent Tube
standard on 6.2 models
(optional on 6.3 & 6.1 models)

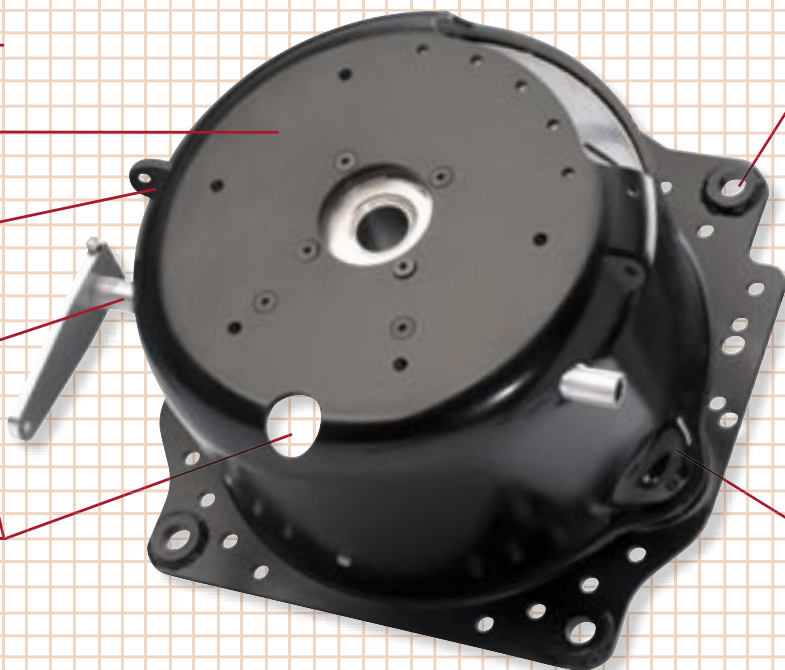

Smallest formed Starter Pocket in the industry

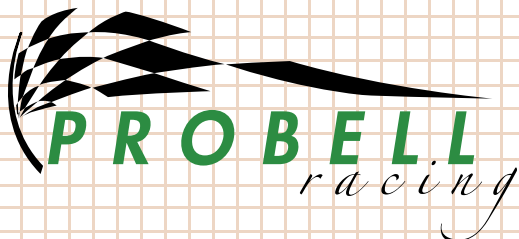

TOP HAT BELLHOUSINGS

WITH STARTER
POCKETS

Part Number	Bellhousing Depth	Starter Pocket*	Engine	Transmission	Inspection Window	Adjustment Slot	Cross Shaft or Fork	SFI Certifications	Description	
BELLHOUSINGS FOR 3 and MOST 4 DISC CLUTCHES										
	610005	8 5/8"	Yes	Chevy/Hemi	Lenco	No	No	Cross Shaft	6.3 & 6.1	Excellent for three and most four disc clutches. Dragsters, Funny Cars, Competition Eliminator, Truck and Tractor Pullers.
+	610006	8 5/8"	Yes	Chevy/Hemi	Lenco	Yes	Yes	Cross Shaft	6.3 & 6.1	
+	610036	8 5/8"	Yes	Chevy/Hemi	ProFab-Rev.	Yes	Yes	Cross Shaft	6.3	Truck and Tractor Pullers, Sand Drag and Mud Racers. Three and most four disc clutches. ProFab Reverser transmission pattern.
+	610038	8 5/8"	Yes	Chevy/Hemi	SCS-Rev.	Yes	Yes	Cross Shaft	6.3	Truck and Tractor Pullers, Sand Drag and Mud Racers. Three and most four disc clutches. SCS Reverser transmission pattern.
	610040	8 5/8"	Yes	Chevy/Hemi	SCS-CC	Yes	Yes	Cross Shaft	6.3	Truck and Tractor Pullers, Sand Drag and Mud Racers. Three and most four disc clutches. SCS Counter Shaft transmission pattern.
+	610042	8 5/8"	Yes	Ford/Ford	ProFab-Rev.	Yes	Yes	Cross Shaft	6.3	429-460 Ford. Pullers, Sand Drag and Mud Racers. Three and most four disc clutches. ProFab Reverser transmission pattern.
+	610044	8 5/8"	Yes	Ford/Ford	SCS-Rev.	Yes	Yes	Cross Shaft	6.3	429-460 Ford. Pullers, Sand Drag and Mud Racers. Three and most four disc clutches. SCS Reverser transmission pattern.
	610046	8 5/8"	Yes	Ford/Ford	SCS-CC	Yes	Yes	Cross Shaft	6.3	429-460 Ford. Pullers, Sand Drag and Mud Racers. Three and most four disc clutches. SCS Counter Shaft transmission pattern.
	610048	8 5/8"	Yes	Chevy/Hemi	ProFab-Rev.	No	No	Cross Shaft	6.3	Truck and Tractor Pullers, Sand Drag and Mud Racers. Three and most four disc clutches. ProFab Reverser transmission pattern.
	610050	8 5/8"	Yes	Chevy/Hemi	SCS-Rev.	No	No	Cross Shaft	6.3	Truck and Tractor Pullers, Sand Drag and Mud Racers. Three and most four disc clutches. SCS Reverser transmission pattern.
	610052	8 5/8"	Yes	Chevy/Hemi	SCS-CC	No	No	Cross Shaft	6.3	Truck and Tractor Pullers, Sand Drag and Mud Racers. Three and most four disc clutches. SCS Counter Shaft transmission pattern.
	610054	8 5/8"	Yes	Ford/Ford	ProFab-Rev.	No	No	Cross Shaft	6.3	429-460 Ford. Pullers, sand drag and mud racers. Three and most four disc clutches. ProFab Reverser transmission pattern.
	610056	8 5/8"	Yes	Ford/Ford	SCS-Rev.	No	No	Cross Shaft	6.3	429-460 Ford. Pullers, sand drag and mud racers. Three and most four disc clutches. SCS Reverser transmission pattern.
	610058	8 5/8"	Yes	Ford/Ford	SCS-CC	No	No	Cross Shaft	6.3	429-460 Ford. Pullers, sand drag and mud racers. Three and most four disc clutches. SCS Counter Shaft transmission pattern.
BELLHOUSINGS FOR 2 and MOST 3 DISC CLUTCHES Most popular bellhousing for Drag Racing and Truck and Tractor Pullers.										
	610009	8 1/8"	Yes	Chevy/Hemi	Lenco	No	No	Cross Shaft	6.3 & 6.1	Excellent for two and most three disc clutches. Dragsters, Funny Cars, Competition Eliminator, Truck and Tractor pullers.
+	610010	8 1/8"	Yes	Chevy/Hemi	Lenco	Yes	Yes	Cross Shaft	6.3 & 6.1	
+	610037	8 1/8"	Yes	Chevy/Hemi	ProFab-Rev.	Yes	Yes	Cross Shaft	6.3	Truck and Tractor Pullers, Sand Drag and Mud Racers. Two and most three disc clutches. ProFab Reverser transmission pattern.
+	610039	8 1/8"	Yes	Chevy/Hemi	SCS-Rev.	Yes	Yes	Cross Shaft	6.3	Truck and Tractor Pullers, Sand Drag and Mud Racers. Two and most three disc clutches. SCS Reverser transmission pattern.
	610041	8 1/8"	Yes	Chevy/Hemi	SCS-CC	Yes	Yes	Cross Shaft	6.3	Truck and Tractor Pullers, Sand Drag and Mud Racers. Two and most three disc clutches. SCS Counter Shaft transmission pattern.
+	610043	8 1/8"	Yes	Ford/Ford	ProFab-Rev.	Yes	Yes	Cross Shaft	6.3	429-460 Ford. Pullers, Sand Drag and Mud Racers. Two and most three disc clutches. ProFab Reverser transmission pattern.
+	610045	8 1/8"	Yes	Ford/Ford	SCS-Rev.	Yes	Yes	Cross Shaft	6.3	429-460 Ford. Pullers, Sand Drag and Mud Racers. Two and most three disc clutches. SCS Reverser transmission pattern.
	610047	8 1/8"	Yes	Ford/Ford	SCS-CC	Yes	Yes	Cross Shaft	6.3	429-460 Ford. Pullers, Sand Drag and Mud Racers. Two and most three disc clutches. SCS Counter Shaft transmission pattern.

+ Our standard in-stock bellhousings. Other bellhousings may require special ordering.
* Maximum flywheel diameter is 14 inches (168 tooth).



**SMALLEST FORMED
STARTER POCKET IN
THE INDUSTRY**

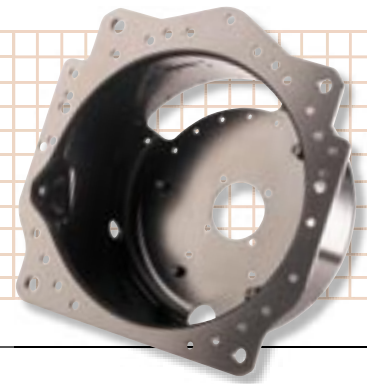

Part Number	Bellhousing Depth	Starter Pocket *	Engine	Transmission	Inspection Window	Adjustment Slot	Cross Shaft or Fork	SFI Certifications	Description
BELLOUSINGS FOR 2 and 3 DISC CLUTCHES (continued)									
610049	8 1/8"	Yes	Chevy/Hemi	ProFab-Rev.	No	No	Cross Shaft	6.3	Truck and Tractor Pullers, Sand Drag and Mud Racers. Two and most three disc clutches. ProFab Reverser transmission pattern.
610051	8 1/8"	Yes	Chevy/Hemi	SCS-Rev.	No	No	Cross Shaft	6.3	Truck and Tractor Pullers, Sand Drag and Mud Racers. Two and most three disc clutches. SCS Reverser transmission pattern.
610053	8 1/8"	Yes	Chevy/Hemi	SCS-CC	No	No	Cross Shaft	6.3	Truck and Tractor Pullers, Sand Drag and Mud Racers. Two and most three disc clutches. SCS Counter Shaft transmission pattern.
610055	8 1/8"	Yes	Ford/Ford	ProFab-Rev.	No	No	Cross Shaft	6.3	429-460 Ford. Pullers, Sand Drag and Mud Racers. Two and most three disc clutches. ProFab Reverser transmission pattern.
610057	8 1/8"	Yes	Ford/Ford	SCS-Rev.	No	No	Cross Shaft	6.3	429-460 Ford. Pullers, Sand Drag and Mud Racers. Two and most three disc clutches. SCS Reverser transmission pattern.
610059	8 1/8"	Yes	Ford/Ford	SCS-CC	No	No	Cross Shaft	6.3	429-460 Ford. Pullers, Sand Drag and Mud Racers. Two and most three disc clutches. SCS Counter Shaft transmission pattern.
BELLOUSINGS FOR TWIN DISC and ADJUSTABLE SINGLE DISC CLUTCHES									
610013	7 1/2"	Yes	Chevy/Hemi	Lenco	No	No	Cross Shaft	6.3 & 6.1	Excellent for twin and adjustable single disc clutches. Same depth as Mopar stock bellhousing. Pro-Mod, Top Sportsmen, Truck and Tractor Pullers.
610014	7 1/2"	Yes	Chevy/Hemi	Lenco	Yes	Yes	Cross Shaft	6.3 & 6.1	
BELLOUSINGS FOR SINGLE DISC and STOCK CLUTCHES									
610015	6 7/16"	Yes	Chevy/Hemi	Lenco	No	No	Cross Shaft	6.3 & 6.1	1/8" deeper than stock Chevrolet bellhousing. Will fit most single disc adjustable clutches and all stock style clutches.
610016	6 7/16"	Yes	Chevy/Hemi	Lenco	Yes	No	Cross Shaft	6.3 & 6.1	
610023	6 7/16"	Yes	Chevy/Hemi	Lenco	Yes	No	Fork	6.1	1/8" deeper than stock Chevrolet bellhousing. Will fit most single disc adjustable clutches and all stock style clutches.
610024	6 7/16"	Yes	Chevy/Hemi	Lenco	No	No	Fork	6.1	
BELLOUSINGS FOR PRO STOCK, SUPER STOCK, STOCK and ET BRACKET CLASSES									
610017	8 5/8"	Yes	Chevy/Hemi	Lenco	Yes	Yes	Fork	6.1	Pro Stock, Super Stock and Stock classes or ET Bracket Cars. Single to four disc clutches.
610018	8 5/8"	Yes	Chevy/Hemi	Lenco	No	No	Fork	6.1	
610025	8 5/8"	Yes	Chevy/Hemi	Muncie-GF	Yes	Yes	Fork	6.1	Pro Stock, Super Stock and Stock classes or ET Bracket Cars. Muncie, G-Force and Liberty transmission bolt patterns. Up to four disc clutches.
610026	8 5/8"	Yes	Chevy/Hemi	Muncie-GF	No	No	Fork	6.1	
610019	8 1/8"	Yes	Chevy/Hemi	Lenco	Yes	Yes	Fork	6.1	Pro Stock, Super Stock and Stock classes or ET Bracket Cars. Single to three disc clutches.
610020	8 1/8"	Yes	Chevy/Hemi	Lenco	No	No	Fork	6.1	
610027	8 1/8"	Yes	Chevy/Hemi	Muncie-GF	Yes	Yes	Fork	6.1	Pro Stock, Super Stock, Stock classes, and ET Bracket cars. Muncie, G-Force and Liberty transmission bolt patterns. Up to three disc clutches.
610028	8 1/8"	Yes	Chevy/Hemi	Muncie-GF	No	No	Fork	6.1	
610021	7 1/2"	Yes	Chevy/Hemi	Lenco	Yes	Yes	Fork	6.1	Super Stock, Stock classes and ET Bracket Cars. Single and most two disc clutches. Same depth as stock Mopar bellhousing.
610022	7 1/2"	Yes	Chevy/Hemi	Lenco	No	No	Fork	6.1	
+ 610029	7 1/2"	Yes	Chevy/Hemi	Muncie-GF	Yes	Yes	Fork	6.1	Super Stock, Stock classes and ET Bracket Cars. Muncie, G-Force and Liberty transmission bolt patterns. Single and two disc clutches.
+ 610030	7 1/2"	Yes	Chevy/Hemi	Muncie-GF	No	No	Fork	6.1	
+ 610031	6 7/16"	Yes	Chevy/Hemi	Muncie-GF	Yes	No	Fork	6.1	Super Stock, Stock classes and ET Bracket Cars. Muncie, G-Force and Liberty transmission bolt patterns. Single disc adjustable and stock clutches.
+ 610032	6 7/16"	Yes	Chevy/Hemi	Muncie-GF	No	No	Fork	6.1	

+ Our standard in-stock bellhousings. Other bellhousings may require special ordering.
* Maximum flywheel diameter is 14 inches (168 tooth).



TOP HAT BELLHOUSINGS

WITHOUT STARTER POCKETS

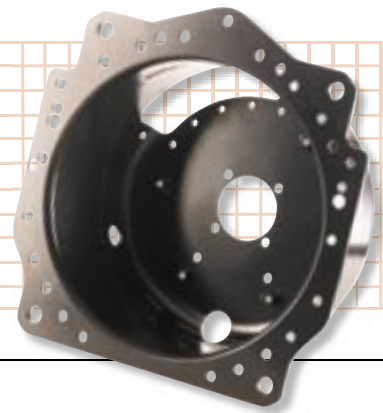

Part Number	Bellhousing Depth	Starter Pocket *	Engine	Transmission	Inspection Window	Adjustment Slot	Cross Shaft or Fork	SFI Certifications	Description
BELLHOUSINGS FOR 5 & 6 DISC CLUTCHES									
610001	9 7/16"	No	Chevy/Hemi	Lenco	No	No	Cross Shaft	6.2	Deepest steel bellhousing available. Will work with five and six disc clutches. Dragsters, Funny Cars, Truck and Tractor Pullers. Lots of room for any style adjustable clutch. Filter vent tube and blow back brackets included.
610002	9 7/16"	No	Chevy/Hemi	Lenco	Yes	Yes	Cross Shaft	6.2	
610033	9 7/16"	No	Donovan/Chevy	Lenco	Yes	Yes	Cross Shaft	6.2	
BELLHOUSINGS FOR 3 & 4 DISC CLUTCHES									
610003	8 5/8"	No	Chevy/Hemi	Lenco	No	No	Cross Shaft	6.2	Excellent for three and most four disc clutches. Dragsters, Funny Cars, Competition Eliminator, Truck and Tractor Pullers. Very popular bellhousing for nostalgia cars with three disc clutches. Filter vent tube and blow back brackets included.
610004	8 5/8"	No	Chevy/Hemi	Lenco	Yes	Yes	Cross Shaft	6.2	
610034	8 5/8"	No	Donovan/Chevy	Lenco	Yes	Yes	Cross Shaft	6.2	
BELLHOUSINGS FOR 2 & 3 DISC CLUTCHES									
610035	8 1/8"	No	Donovan/Chevy	Lenco	Yes	Yes	Cross Shaft	6.2	Excellent for two and most three disc clutches. Dragsters, Funny Cars, Nostalgia Cars, Competition Eliminator, Truck and Tractor Pullers. Filter vent tube and blow back brackets included.
610007	8 1/8"	No	Chevy/Hemi	Lenco	No	No	Cross Shaft	6.2	
610008	8 1/8"	No	Chevy/Hemi	Lenco	Yes	Yes	Cross Shaft	6.2	
BELLHOUSINGS FOR TWIN DISC & ADJUSTABLE SINGLE DISC CLUTCHES									
610011	7 1/2"	No	Chevy/Hemi	Lenco	No	No	Cross Shaft	6.2	Excellent for twin and adjustable single disc clutches. Same depth as stock Mopar bellhousing. Dragsters, Funny Cars, Top Sportsmen, Truck and Tractor Pullers
610012	7 1/2"	No	Chevy/Hemi	Lenco	Yes	Yes	Cross Shaft	6.2	

† Our standard in-stock bellhousings. Other bellhousings may require special ordering.
* Maximum flywheel diameter is 14 inches (168 tooth).



Photo courtesy of <http://www.olliescandids.photorelect.com>

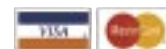

TOP HAT BELLHOUSINGS ACCESSORIES



Letter (see photo)	Part Number	Description
A	710001	Bearing Retainer: Billet Aluminum with dual sensor pick ups
B	710002	Cross Shaft Arm: Billet Aluminum, 6" length with a 1/4" hole for clutch linkage hookup
C	710003	Cross Shaft: each end splined for easy clutch linkage hookup in any chassis
D	710004	Fork: Billet Aluminum or Billet Steel, fits all manufacturers cross shafts Browell, Lakewood, and Trick Titanium
	710010	4" Universal Clutch Return Spring
	710011	Replacement cover bolts 5/16" - 24 x 1/2" Grade 8
	710012	3/4" Anti-Rotator Studs and Nuts Grade 8
E	710047	3/4" Anti-Rotator Bolt and Nut Kit Grade 8
	710013	1/2" Anti-Rotator Studs and Nuts Grade 8
F	710014	3/8" Bolt and Nut Kit Grade 8
G	710015	3/8" Stud and Nut Kit Grade 8
H	710016	7/16" Bolt and Nut Kit Grade 8
I	710017	7/16" Stud and Nut Kit Grade 8
J	710018	Throwout Bearing, 1.3" long (shown)
J	710019	Throwout Bearing, 1.9" long
	710023	Mid plate 6061-T6 Aluminum 1/4" thick machined with bellhousing and containment pattern with center line marks
	710024	Mid plate 4130 Chrome Moly Steel 1/4" thick machined with bellhousing and containment pattern with center line marks
	710025	6.1 SFI Block Plate: 1/8" steel with machined bellhousing pattern
	710027	Replacement 5/16" - 24 x 1/2" Counter Sunk SHCS for cross shaft supports & bearing retainer
	710036	Clutch Fork Ball Stud 13/16" - 16 x 1.48 GM style



OUR MISSION

To be a company focused on producing and supplying the highest quality racing parts that fulfill our customer's specific needs. We will be diligent in our efforts to always keep our customers ahead of the competition, while also staying focused on the needs of our shareholders.

PRODUCT CAUTION STATEMENT

The products represented in this catalog may not be modified or altered in any manner other than by the manufacturer and must be used strictly in accordance with its intended purpose. Any such modification or alteration of this product will void the manufacturer's warranty relating thereto and the product's SFI certification. Modifications and alterations include, but are not limited to, [chrome or zinc plating, welding, cutting, grinding or heating]. All users of the product are advised that modifications and alterations of the enclosed product may reduce the product's safety and reliability and may result in death or serious injury to person or property. Any party that modifies or alters these products may be subject to liability for injuries and damages suffered by other parties as a result of such modification or alteration.



305 N. CENTER STREET
WEST LAFAYETTE, OH 43845



www.probellracing.com • 888.539.9566

If it doesn't say PROBELL, it's just a CAN.